

GATE OPERATOR

**BIG**

**25QI**

**230 V**

Up to  
2500 kg

Speed up to  
19 m/min

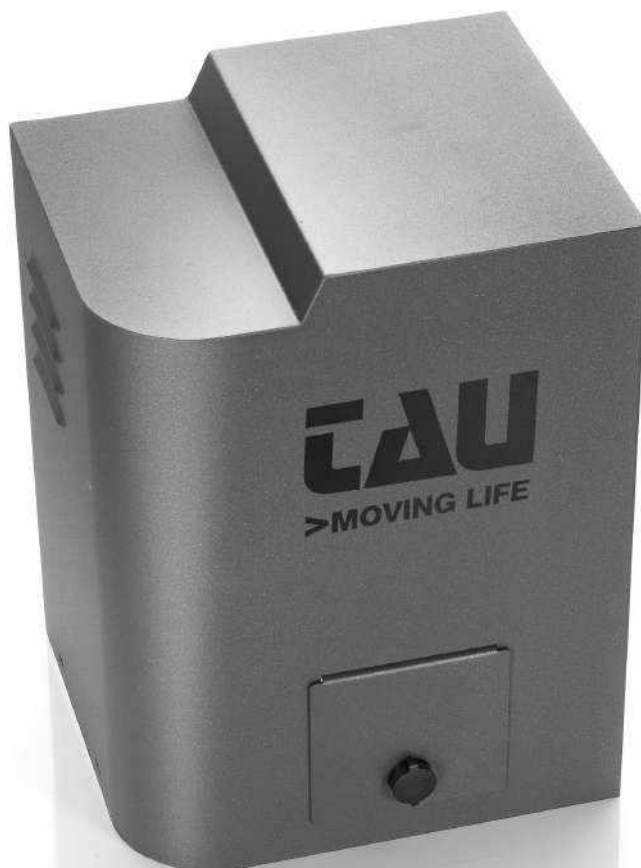

### **500BIG25QI**

230 V three-phase sliding gate operator with builtin control unit with inverter. Maximum gate weight 2500 kg.



**Accessories for  
BIG series**  
Page 46



**Further accessories:**  
Transmitters page 234  
Photocells page 239  
Flashing lights  
page 242



## FEATURES:

- commercial use
- for gates up to 2500 kg
- three-phase 230 V operator
- mono-phase 230 V power supply
- soft start and soft stop
- adjustable opening and closing speed of the control unit and inverter
- oil bath vertical pinion operator
- painted steel housing
- manual release mechanism
- anti-crush adjustable mechanical clutch

## PROS:

- suitable for large sliding gates
- higher torque and power thanks to the inverter technology
- self-ventilated operator for intensive use
- metal and bronze gears to increase endurance and reduce noise



### UNLOCK

Thanks to the large handle, the unlocking maneuver is always feasible even for particularly heavy gates.



### CLUTCH

Adjustable dry clutch, interposed between the motor and the reducer, for the safeguard of the mechanical parts in case of obstacles to gate movement.



### ENGINE

The ventilated three-phase motor guarantees intensive use.



### ELECTRONICS

The control unit with inverter allows to vary the speed and to program the acceleration and deceleration ramps.

## TECHNICAL DRAWINGS

### Technical features

### BIG25QI

Power supply	230 V AC (50 - 60 Hz)
Motor power supply	230 V AC (three-phase)
Open circuit voltage	3 A
Power rating	1000 W
Max. operating speed	adjustable 5 ÷ 19 m/min
Duty cycle	100 %
Operating temperature	-20° C ÷ +55° C
Motor thermal protection	150° C
Degree of protection	IP 54
Max. gate leaf weight	2500 kg
Pinion module	4
Electronic control unit	D812M25

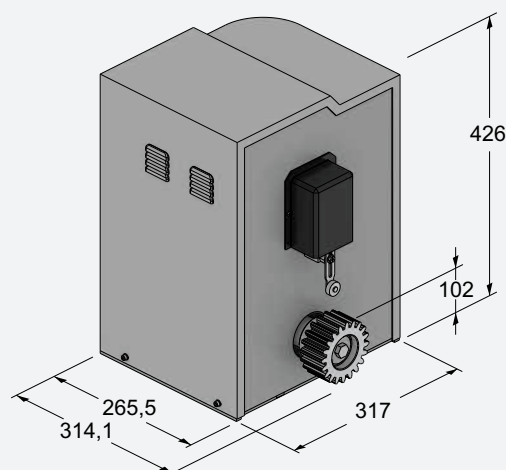

# ACCESSORIES

## BIG SERIES ACCESSORIES



**400CP25**  
Counterplate for BIG25QI



**400CP30**  
Counterplate for BIG40QI

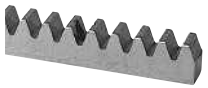

**550CFZ06**  
Steel rack 30x30 (Module 6, max 4000 kg) 2 meter sections. Pcs / Pack 10 m



**M-ING0000Z12BIG**  
Pinion module 6 (BIG40QI)



**400CFZ22**  
Steel rack 22x22 (Module 4, max 3000 kg) 2 meter sections. Pcs / Pack 4 m



**400VSF20**  
Screws and brackets for 400CFZ22 (40 units per pkg)



**400PROFC**  
Galvanized rack attachment profile. 2 meter sections Compatible with 400CFZ22



**900BSD15**  
Deformable safety edge kit / =1,5 m



**700BAP4**  
Gate stopper with spring

**900BSD18**  
Deformable safety edge kit / =1,8 m

**900BSD20**  
Deformable safety edge kit / =2 m

**900BSD25**  
Deformable safety edge kit / =2,5 m



**900TWM**  
Wireless master receiver for max 8 safety edges



**900TWC**  
Mobile wireless slave transmitter for safety edge



**250RXSM2**  
Self-learning, two-channel, 433,92 MHz plug-in radio receiver. Accepts up to 14 rolling code transmitters or unlimited dipswitch transmitters



**250SM126**  
Memory card for 126 radio codes



**C-CRT**  
Warning signal



**C-TARG**  
Aluminium CE mark label, self adhesive



## BIG25QI TYPICAL SYSTEM

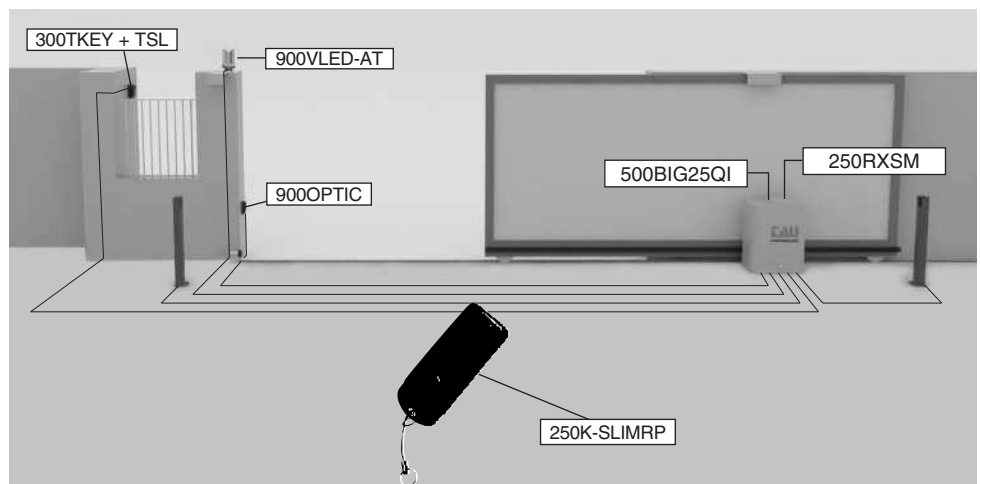

## BIG40QI TYPICAL SYSTEM

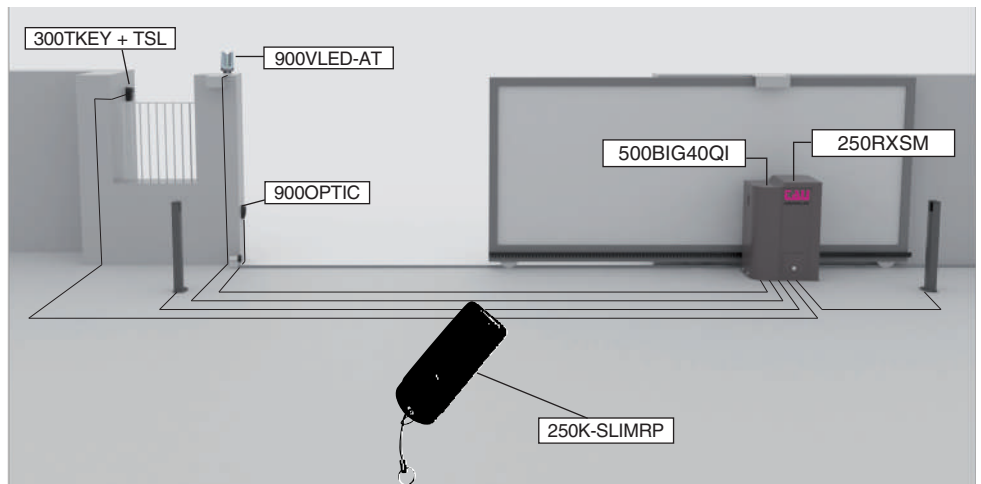

## CHAIN VARIANT

**120 VOLT**

AVAILABLE

Upon request, the BIG gearmotor is available with the pinion for chain transmission and for foreign markets the 120 Volt variant is also available.

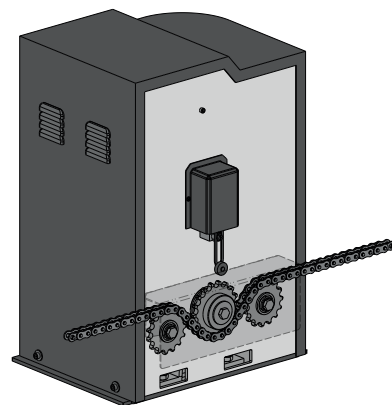

## Use and maintenance manuals



BIG



D812M



D812M25



D812M-110



D703M

